

ref.: **T-528**
 rev. no.: **2**
 date: **11/98**
 page: **11/11**

technical sheet

tracks for building maintenance units (BMU)

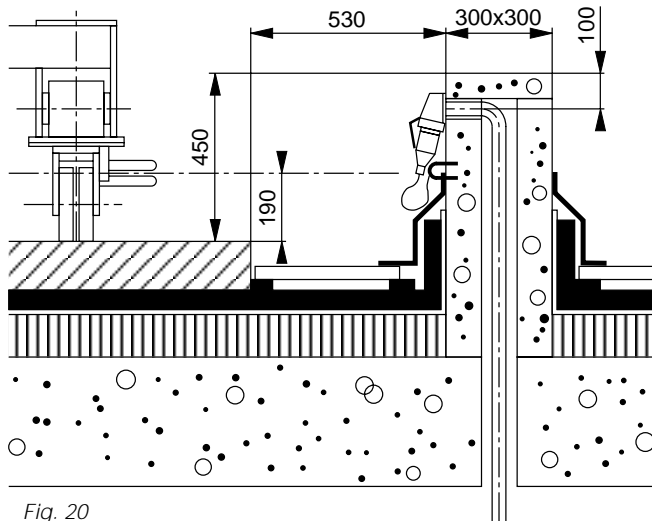

Fig. 20
 Power point on concrete track support plinth

3. Power supply

There should be power points every 40 m along the track (for JUNIOR and SENIOR machines) or every 30 m for MINI machines.

These power points may be fitted to the concrete (Fig. 20) or steel sleepers (Fig. 21).

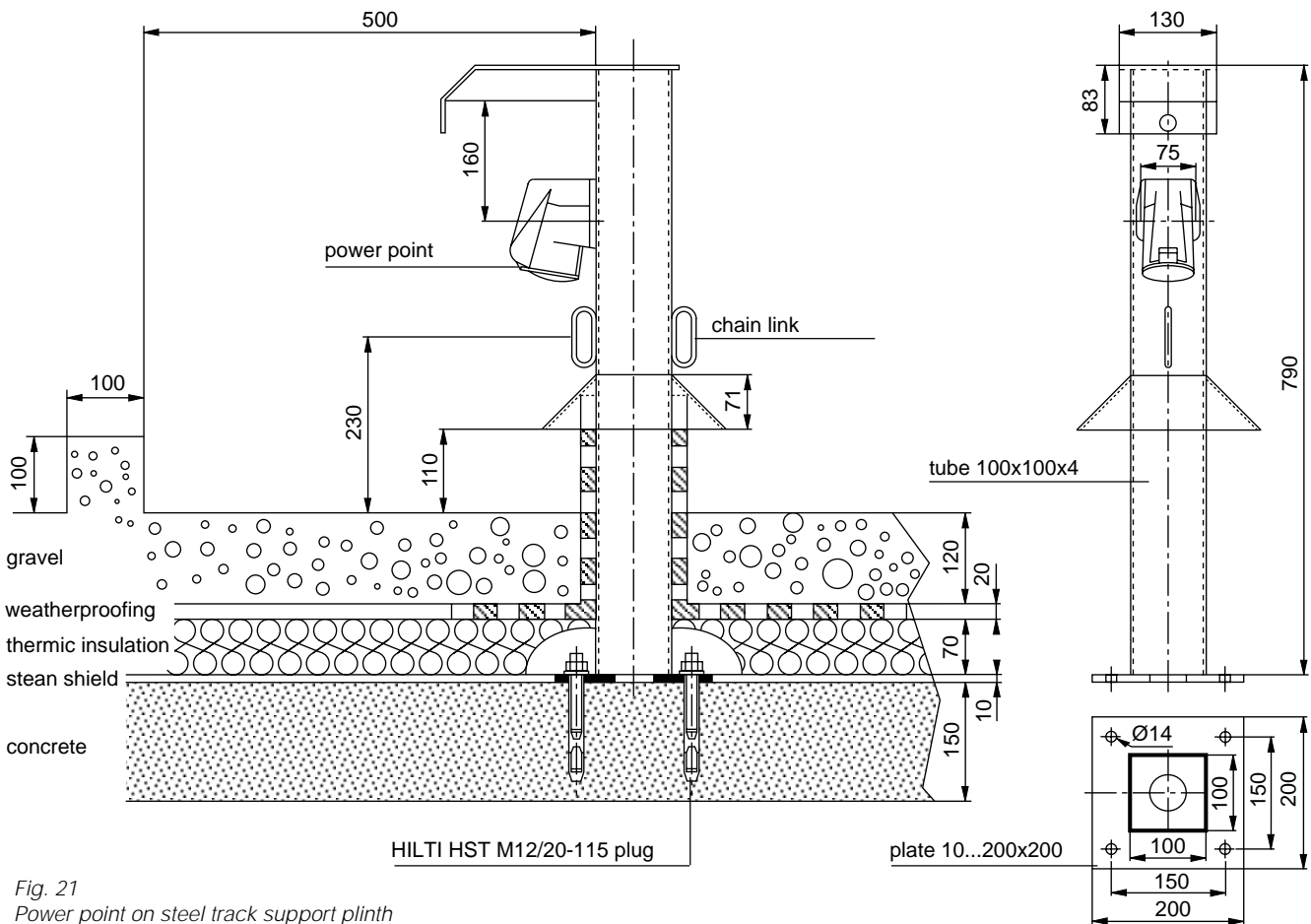

Fig. 21
 Power point on steel track support plinth